



深圳市高信技术有限公司

Shenzhen Gaoxin Technology Co., Ltd

SPECIFICATION

FOR

LCD MODULE

Customer : _____

CustomerP/N _____

Model No. : **GX079-40MB-A1**

Version : **V00**

Date : **2022-05-23**

Final Approval by Customer

LCM Machinery OK <input type="checkbox"/>	Checked By	
LCM Display OK <input type="checkbox"/>	Checked By	
LCM NG <input type="checkbox"/> LCM OK <input type="checkbox"/>	Approved By	

ShenZhen GX Confirmed :

DESIGN	CHECK	APPROVAL

联系人：岳爱福 15989334751 地址：深圳市光明区田寮社区田阔路15号3楼



深圳市高信技术有限公司

Shenzhen Gaoxin Technology Co., Ltd

Table of Contents

Revision History	3
1 General Specifications	4
2 Pin Assignment	5
3 Absolute Maximum Ratings	6
4 Electrical Characteristics	6
5 INTERFACE TIMING	8
6 Optical Characteristics	10
7 Environmental / Reliability Test	15
8 Mechanical Drawing	16
9 Precautions For Use of LCD Modules	16



深圳市高信技术有限公司

Shenzhen Gaoxin Technology Co., Ltd

Revision History

Rev	Issued Date	Description	Page	Editor
1.0	Apr.28,2022	First release	All	



深圳市高信技术有限公司

Shenzhen Gaoxin Technology Co., Ltd

1 General Specifications

	Feature	Specifications
Display Spec.	LCD type	7.84 inch
	Resolution (H*V)	400*(RGB)*1280
	Technology Type	a-Si TFT
	Pixel Configuration	R.G.B. Vertical Stripe
	Normally White	Normally Black
	Viewing Direction	ALL
Mechanical Characteristics	OutlineDimensions (W x H x T) (mm)	67.8*206.18*4.6
	Active Area(mm)	59.4*190.08
	With /Without Touch screen	Without
	Match Connector Type	40PIN 0.5PITCH
	Backlight Type	LED
	Weight (g)	TBD
Electrical Characteristics	Interface	MIPI 4lane
	Number of color	16.7M
	Driver IC	NV3051



深圳市高信技术有限公司

Shenzhen Gaoxin Technology Co., Ltd

2 Pin Assignment

Pin No.	Symbol	Function
1	GND	Ground
2	D0P	MIPI Data lane0 input (positive)
3	D0N	MIPI Data lane0 input (negative)
4	GND	Ground
5	D1P	MIPI Data lane1 input (positive)
6	D1N	MIPI Data lane1 input(negative)
7	GND	Ground
8	CLKP	MIPI CLK input (positive)
9	CLKN	MIPI CLK input (negative)
10	GND	Ground
11	D2P	MIPI Data lane2 input (positive)
12	D2N	MIPI Data lane2 input (negative)
13	GND	Ground
14	D3P	MIPI Data lane3 input (positive)
15	D3N	MIPI Data lane3 input (negative)
16-17	GND	Ground
18-19	VCC-1V8	IO Power Supply(1.65V~3.6V)
20-23	NC	NC
24	RSTB	global reset pin. Active low to enter reset state. suggest to connecting with an RC reset circuit for stability. Normally pull high.
25	NC	NC
26	NC	NC
27	GND	Ground
28-29	K	Backlight LED Ground
30	GND	Ground
31	NC	NC
32-33	GND	Ground
34	NC	NC
35-36	A	Backlight LED Power
37	GND	Ground
38-39	VDD-3V3	Power Supply(3.3~3.6V)
40	NC	NC



深圳市高信技术有限公司

Shenzhen Gaoxin Technology Co., Ltd

3 Absolute Maximum Ratings

GND=0V, Ta= 25°C

Item	Symbol	Value	Unit
Power supply voltage for logic	V _{DD}	3.0~3.3	V
Input voltage	V _{in}	V _{DD} +0.3	V
Operating temperature	Topr	-20 to 70	°C
Storage temperature	Tstg	-30 to 80	°C

Note: Note1: Absolute maximum rating is the limit value beyond which the IC maybe broken.

They do not assure operations.

Note2: Background color changes slightly depending on ambient temperature. This Phenomenon is reversible.

4 Electrical Characteristics

4.1 Driving TFT LCD Panel

Item	Symbol	Min	Type	Max	Unit	Test condition
Power voltage	VDD	3.0	3.3	-	V	-
Input logic high voltage	V _{IH}	0.7VDD	-	VDD	V	
Input logic low voltage	V _{IL}	0	-	0.3VDD	V	

4.2 Driving Backlight

Ta=25°C

Item	Symbol	Min	Typ	Max	Unit	Remark
Forward Current	I _F	--	80	--	mA	
Forward Voltage	V _F	-	19.2	-	V	
Connection mode	-	--	6S4P	--		
LED number	/		24		pcs	
LED Life			20000		Hrs	

Note1: Optical performance should be evaluated at Ta=25°C only .If LED is driven by high current, high ambient temperature & humidity condition. The life time of LED will be reduced. Operating life means brightness goes down to 50% initial brightness. Typical operating life time is estimated data.

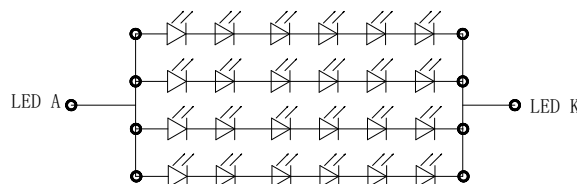

I_f=80mA, V_f=19.2V (TYP)



深圳市高信技术有限公司

Shenzhen Gaoxin Technology Co., Ltd

4.3 Block Diagram

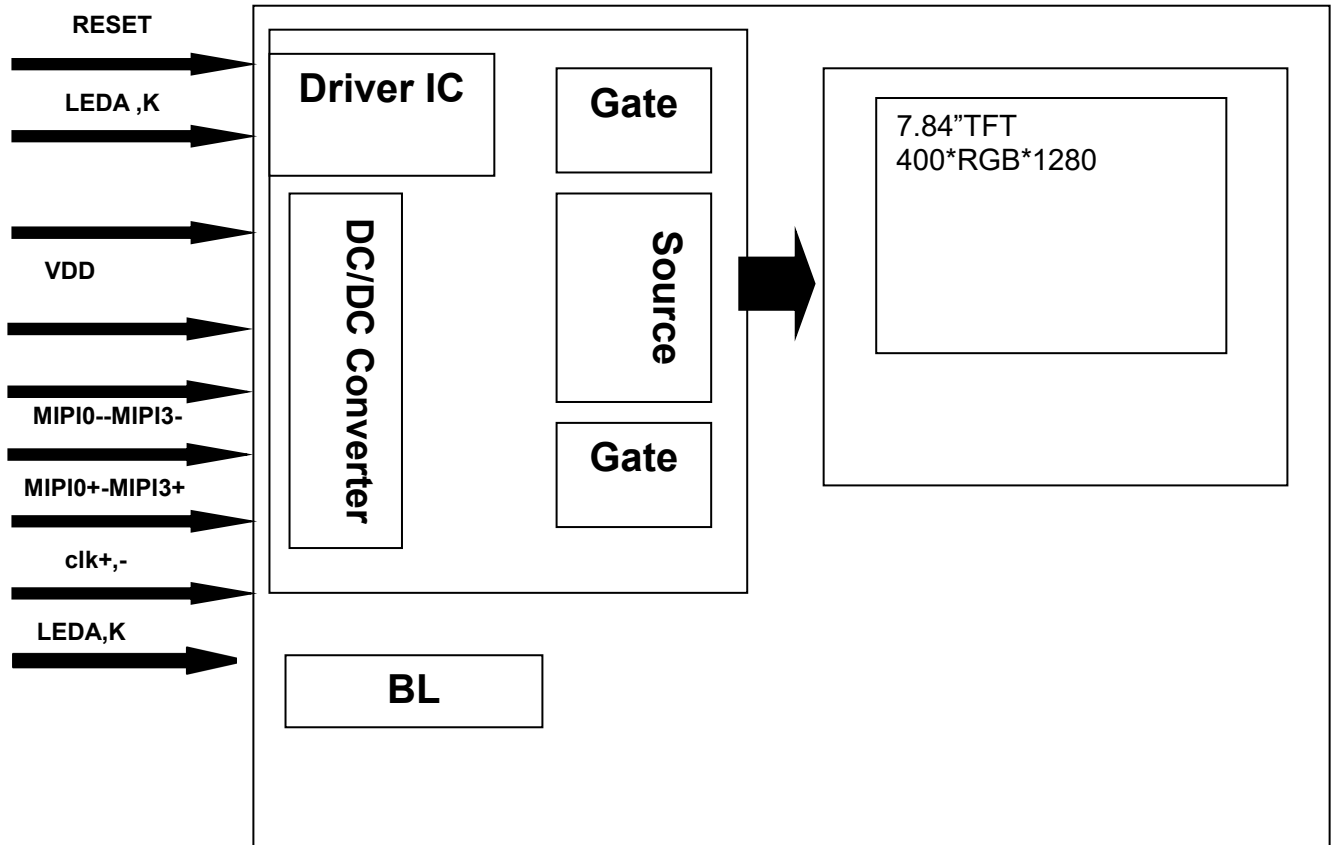



5 INTERFACE TIMING

Data input format for MIPI

Parameter	Symbol	Parameter	Specification			Unit
			MIN	TYP	MAX	
High Speed Mode						
DSI-CLK+/-	$2XU_{inst}$	Double UI instantaneous	2.22	-	25	ns
DSI-CLK+/-	U_{INSTA}, U_{INSTB}	UI instantaneous Halfs	1.11	-	12.5	ns
DSI-Dn+/-	T_{ds}	Data to clock setup time	0.15	-	-	UI
DSI-Dn+/-	T_{dh}	Data to clock hold time	0.15	-	-	UI
DSI-CLK+/-	T_{drclk}	Differential rise time for clock	150	-	0.3UI	ps
DSI-Dn+/-	T_{drdata}	Differential rise time for data	150	-	0.3UI	ps
DSI-CLK+/-	T_{dfclk}	Differential fall time for clock	150	-	0.3UI	ps
DSI-Dn+/-	T_{dfdata}	Differential fall time for data	150	-	0.3UI	ps

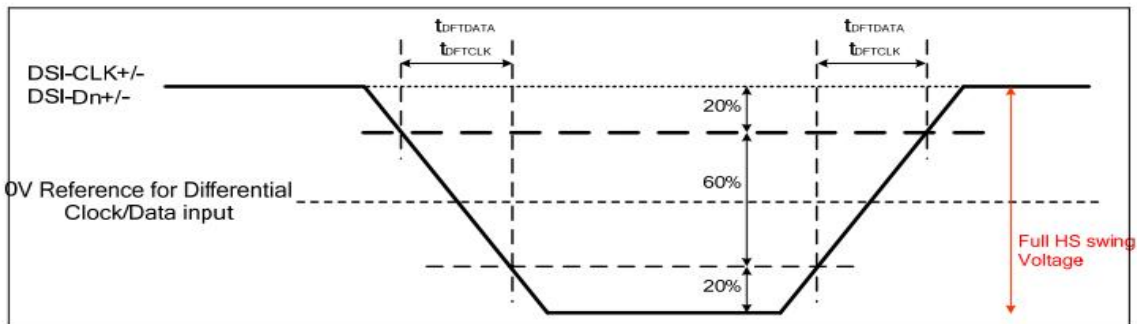
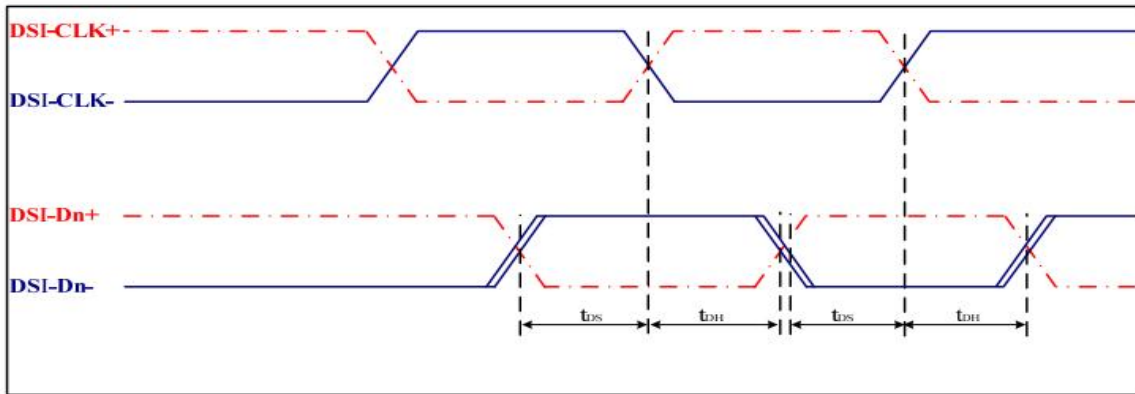
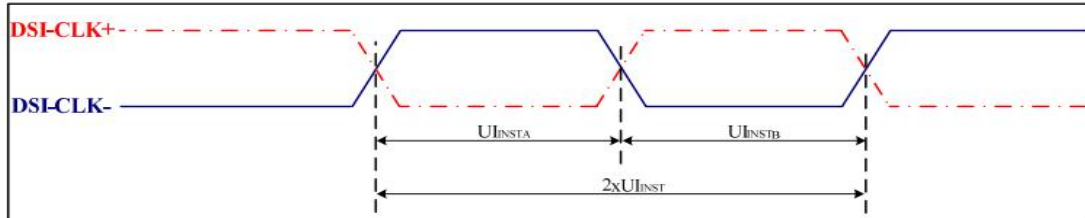

Figure: AC characteristics for MIPI-DSI High speed mode



深圳市高信技术有限公司

Shenzhen Gaoxin Technology Co., Ltd

Low power mode

Parameter	Symbol	Parameter	Specification			Unit
			MIN	TYP	MAX	
Low Power Mode						
DSI-D0+/-	TLPXM	Length of LP-00, LP-01, LP-10 or LP-11 periods MPU Display Module	50	-	-	ns
DSI-D0+/-	TLPXD	Length of LP-00, LP-01, LP-10 or LP-11 periods Display Modulen MPU	58	-	-	ns
DSI-D0+/-	TTA-SURED	Time-out before the MPU start driving	TLPXD	-	2XTLPXD	ns
DSI-D0+/-	TTA-GETD	Time to drive LP-00 by display module	5XTLPXD	-	-	ns
DSI-D0+/-	TTA-GOD	Time to drive LP-00 after turnaround request - MPU	4XTLPXD	-	-	ns
DSI-D0+/-	Ratio TLPX	Ratio of TLPXM / TLPXD between MCU and display module	2/3	-	3/2	

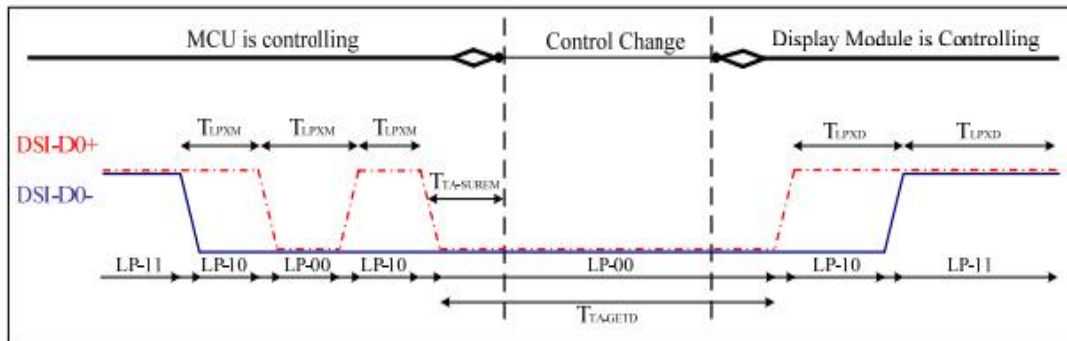

Figure: BTA from the MCU to the Display Module

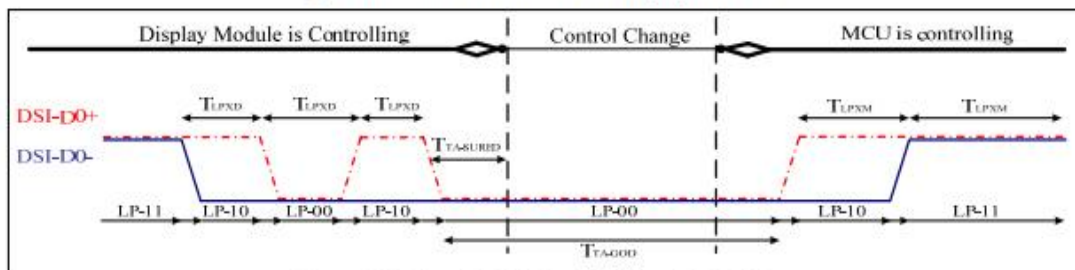
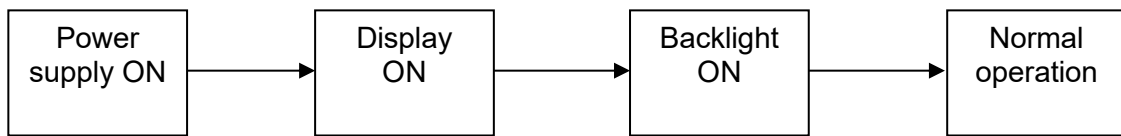
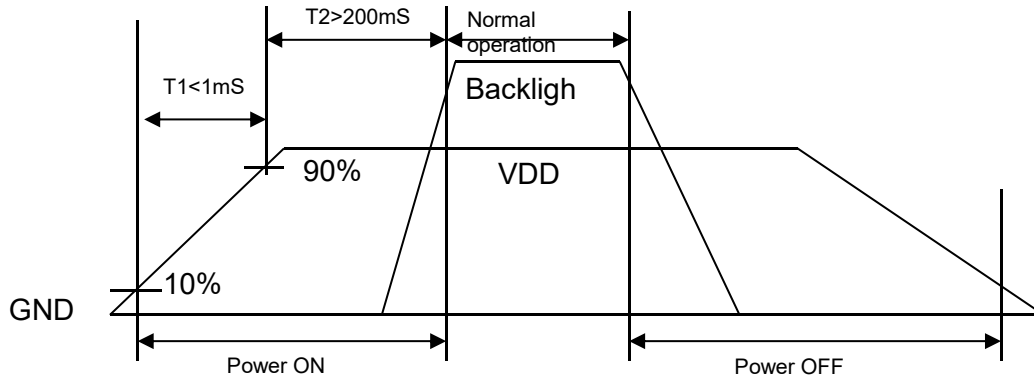

Figure: BTA from the Display Module to the MCU



5.1 Power ON/OFF Timing



Power ON sequence

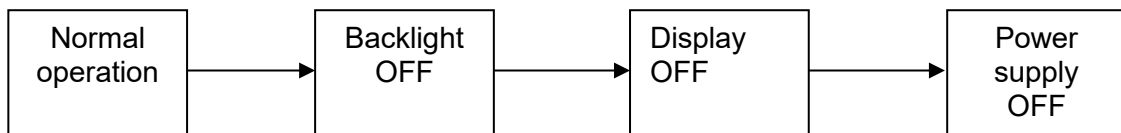

Power OFF sequence



6 Optical Characteristics

Ta=25°C

Item	Symbol	Condition	Min	Typ	Max	Unit	Remark
View Angles	θT	$CR \geq 10$	70	80	-	Degree	Note 2
	θB		70	80	-		
	θL		70	80	-		
	θR		70	80	-		
Contrast Ratio	CR	$\theta=0^\circ$	700	900	-	-	Note1 Note3
Response Time	T_{ON}	25°C	-	25	35	ms	Note1
	T_{OFF}						Note4
Uniformity	U	-	75	80	-	%	Note1 Note6
NTSC	-	-	65	70	-	%	Note 5
Luminance	L		-	450	-	cd/m ²	Note1 Note7

Test Conditions:

1. $V_F=19.2V$, $I_F=80mA$, the ambient temperature is 25°C.
2. The test systems refer to Note 1 and Note 2.



深圳市高信技术有限公司

Shenzhen Gaoxin Technology Co., Ltd

Note 1: Definition of optical measurement system.

The optical characteristics should be measured in dark room. After 5 minutes operation, the optical properties are measured at the center point of the LCD screen. All input terminals LCD panel must be ground when measuring the center area of the panel.

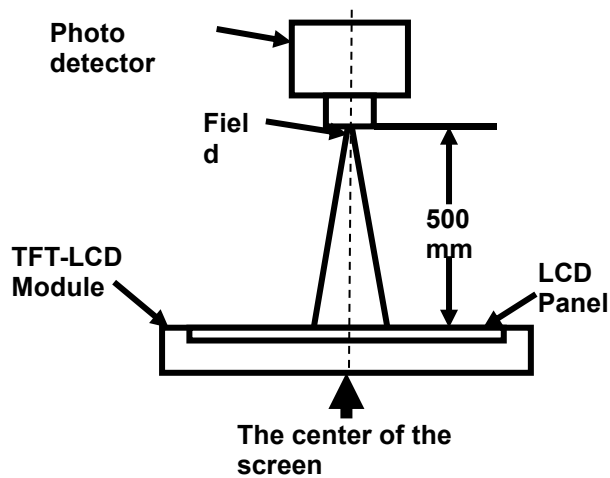

Item	Photo detector	Field
Contrast Ratio	SR-3A	1°
Luminance		
Chromaticity		
Lum Uniformity		
Response Time	BM-7A	2°

Note 2: Definition of viewing angle range and measurement system.

viewing angle is measured at the center point of the LCD by CONOSCOPE(ergo-80).

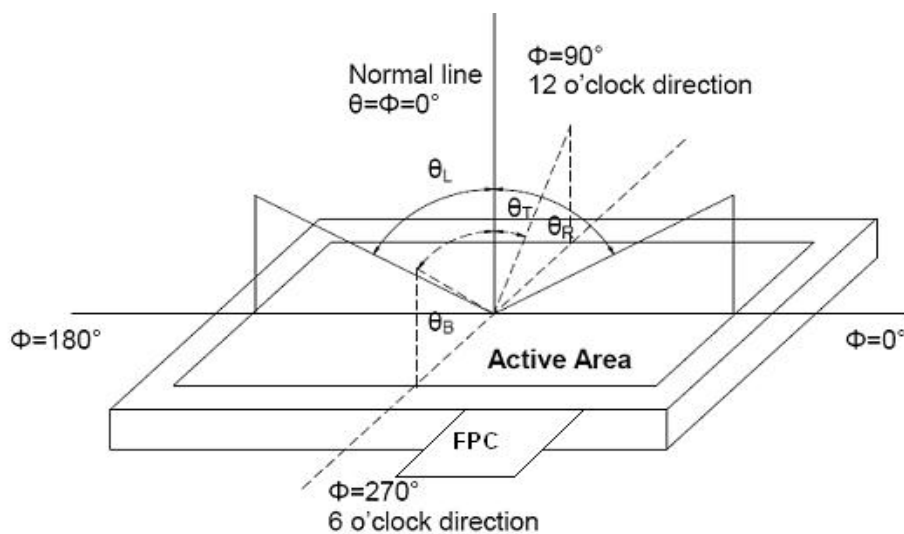

Fig. 1 Definition of viewing angle



深圳市高信技术有限公司

Shenzhen Gaoxin Technology Co., Ltd

Note 3: Definition of contrast ratio

$$\text{Contrast ratio (CR)} = \frac{\text{Luminance measured when LCD is on the "White" state}}{\text{Luminance measured when LCD is on the "Black" state}}$$

“White state “:The state is that the LCD should be driven by Vwhite.

“Black state”: The state is that the LCD should be driven by Vblack.

Vwhite: To be determined Vblack: To be determined.

Note 4: Definition of Response time

The response time is defined as the LCD optical switching time interval between “White” state and “Black” state. Rise time (TON) is the time between photo detector output intensity changed from 90% to 10%. And fall time (TOFF) is the time between photo detector output intensity changed from 10% to 90%.

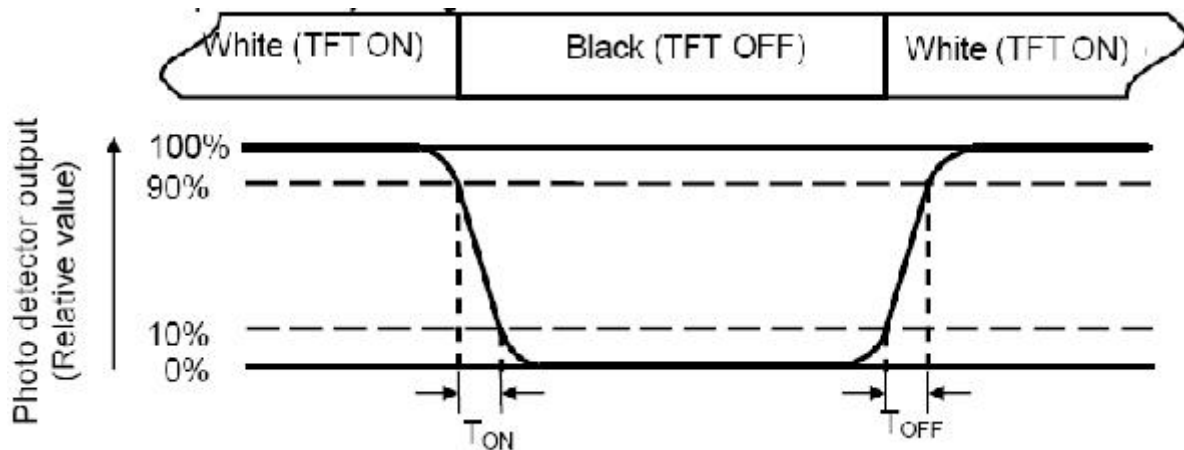

Note 5: Definition of color chromaticity (CIE1931)

Color coordinates measured at center point of LCD.



深圳市高信技术有限公司

Shenzhen Gaoxin Technology Co., Ltd

Note 6: Definition of Luminance Uniformity

Active area is divided into 9 measuring areas (Refer Fig. 2). Every measuring point is placed at the center of each measuring area.

Luminance Uniformity (U) = L_{min} / L_{max}

L-----Active area length W----- Active area width

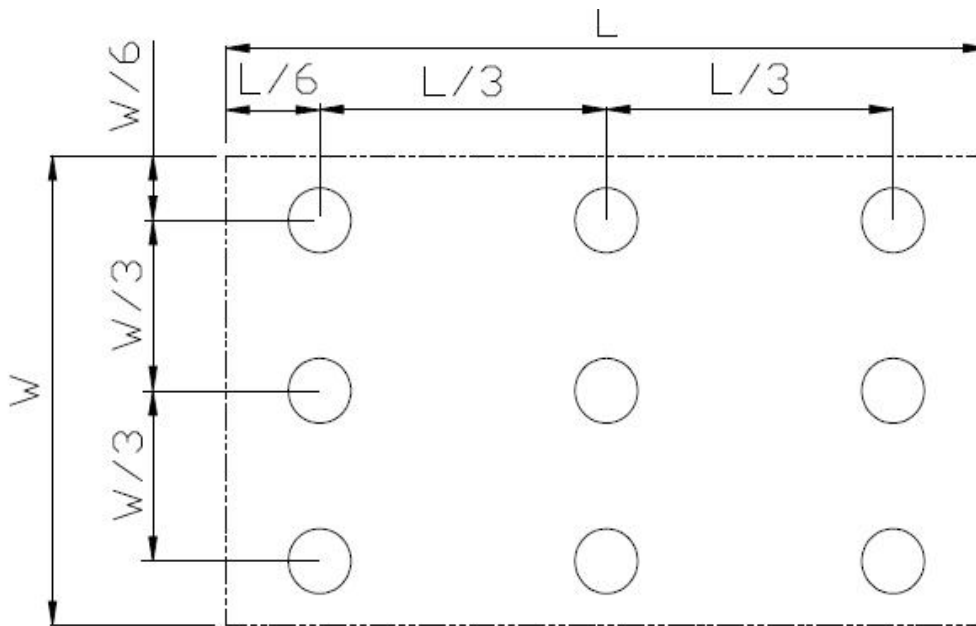

Fig. 2 Definition of uniformity

L_{max} : The measured maximum luminance of all measurement position.

L_{min} : The measured minimum luminance of all measurement position.

Note 7: Definition of Luminance:

Measure the luminance of white state at center point.



7 Environmental / Reliability Test

Item	Condition	Time (hrs)	Assessment
High temp. Storage	80°C	120	No abnormalities in functions and appearance
High temp. Operating	70°C	120	
Low temp. Storage	-30°C	120	
Low temp. Operating	-20°C	120	
Humidity	60°C/ 90%RH	120	
Thermal Shock(Non-operation)	-0°C ← 25°C →70°C (0.5 hour ← 5 min → 0.5 hour)	10cycles	

Remark:

- 1.The test samples should be applied to only one test item.
- 2.Sample size for each test item is 1~10pcs.
- 3.In case of malfunction defect caused by ESD damage, if it would be recovered to normal state after resetting, it would be judged as a good part.



8 Mechanical Drawing

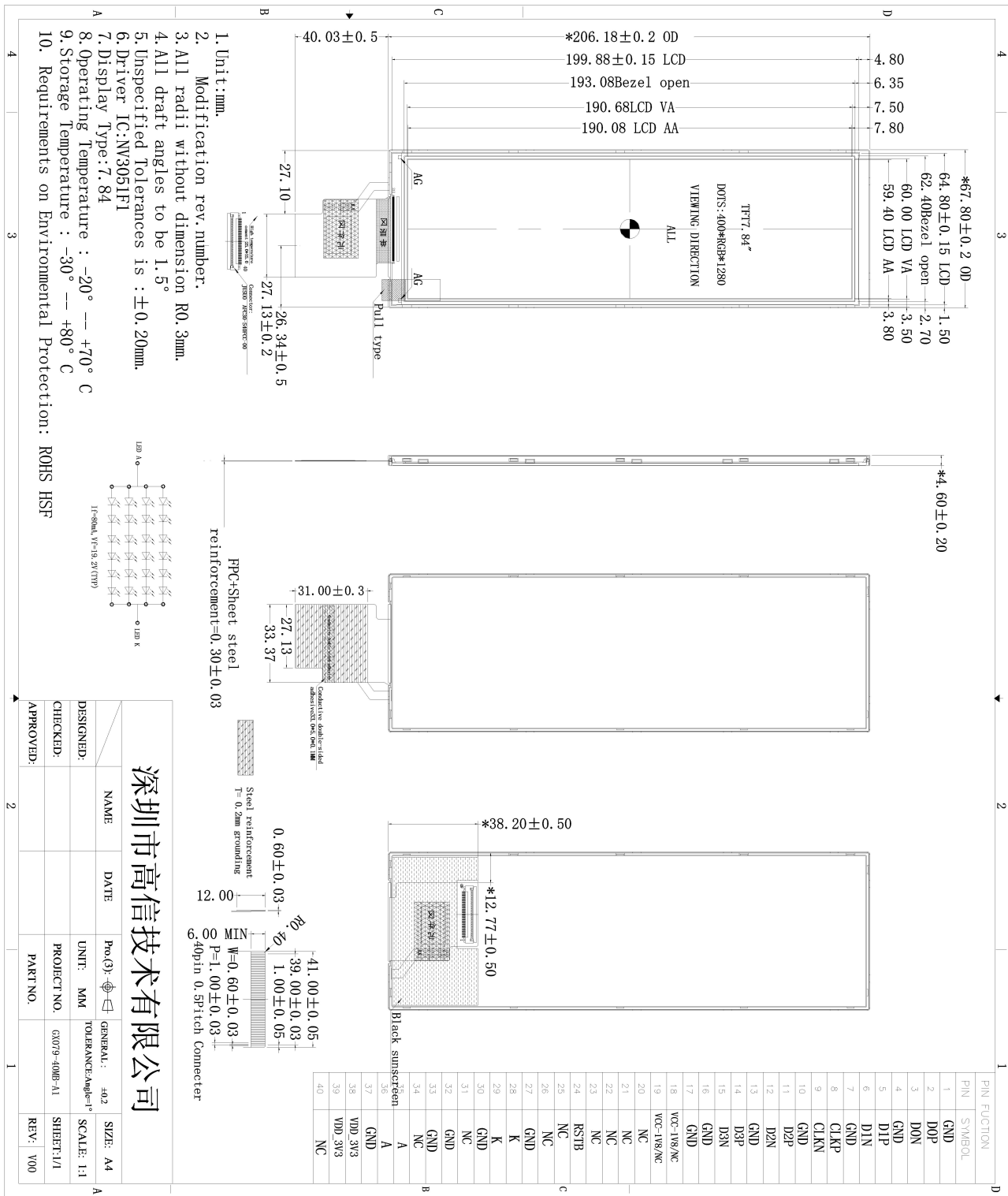

深圳市高信技术有限公司

DESIGNED:	NAME	DATE	UNIT: ①	GENERAL: f0.2	SIZE: A4
CHECKED:			PROJECT NO. GX079-40MB-A1	TOLERANCE: angle=1°	SCALE: 1:1
APPROVED:			PAK1 NO.		SHEET: 1/1
					REV: V00

9 Precautions For Use of LCD Modules

9.1 Handling Precautions



深圳市高信技术有限公司

Shenzhen Gaoxin Technology Co., Ltd

9.1.1.1 The display panel is made of glass. Do not subject it to a mechanical shock by dropping it from a high place, etc.

9.1.1.2 If the display panel is damaged and the liquid crystal substance inside it leaks out, be sure not to get any in your mouth, if the substance comes into contact with your skin or clothes, promptly wash it off using soap and water.

9.1.1.3 Do not apply excessive force to the display surface or the adjoining areas since this may cause the color tone to vary.

9.1.1.4 The polarizer covering the display surface of the LCD module is soft and easily scratched. Handle this polarizer carefully.

9.1.1.5 If the display surface is contaminated, breathe on the surface and gently wipe it with a soft dry cloth. If still not completely clear, moisten cloth with one of the following solvents:

- Isopropyl alcohol
- Ethyl alcohol

Solvents other than those mentioned above may damage the polarizer. Especially, do not use the following:

- Water
- Ketone
- Aromatic solvents

9.1.1.6 Do not attempt to disassemble the LCD Module.

9.1.1.7 If the logic circuit power is off, do not apply the input signals.

9.1.1.8 To prevent destruction of the elements by static electricity, be careful to maintain an optimum work environment.

9.1.1.9 Be sure to ground the body when handling the LCD Modules.

9.1.1.10 Tools required for assembly, such as soldering irons, must be properly ground.

9.1.1.11 To reduce the amount of static electricity generated, do not conduct assembly and other work under dry conditions.

9.1.1.12 The LCD Module is coated with a film to protect the display surface. Be care when peeling off this protective film since static electricity may be generated.

9.1.1.13 Storage precautions

9.1.1.14 When storing the LCD modules, avoid exposure to direct sunlight or to the light of fluorescent lamps.

9.1.1.15 The LCD modules should be stored under the storage temperature range. If the LCD modules will be stored for a long time, the recommend condition is:

9.1.1.16 The LCD modules should be stored in the room without acid, alkali and harmful gas.

9.2 Transportation Precautions

The LCD modules should be no falling and violent shocking during transportation, and also should avoid excessive press, water, damp and sunshine.